

MODEL NO. 11HS20-1004D-E1000-EGS100 DWG NO. A6046

CUSTOMER'S MODEL: NO MODEL
END COVER COLOR: BLACK

REV.	REVISION RECORD	BY	DATE
0	ORIGIN	ZPJ	3.23.2026

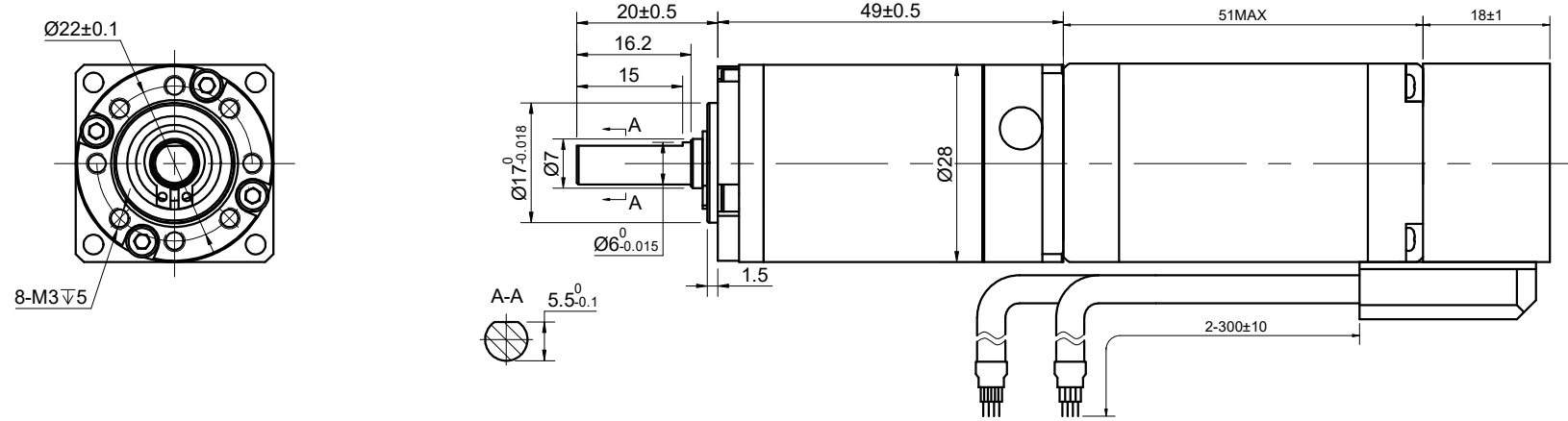

SPECIFICATION	CONNECTION	BIPOLAR
AMPS/PHASE		1.00
RESISTANCE/PHASE(Ohms)@25°C		3.50±10%
INDUCTANCE/PHASE(mH)@1KHz		3.20±20%
HOLDING TORQUE w/o GEARBOX(Nm)[lb-in]		0.14[1.24]
GEAR RATIO		100
EFFICIENCY		90.00%
STEP ANGLE w/o GEARBOX(°)		1.80
STEP ACCURACY(NON-ACCUM)		±5.00%
BACKLASH@NO-LOAD(arcmin)		<=25
MAX.PERMISSIBLE TORQUE(Nm)		6.00
MOMENT PERMISSIBLE TORQUE(Nm)		12.00
SHAFT MAXIMUM AXIAL LOAD(N)		100
SHAFT MAXIMUM RADIAL LOAD(N)		300
AMBIENT TEMPERATURE		-10°C~50°C[14°F~122°F]
INSULATION CLASS		B 130°C[266°F]
TEMPERATURE RISE		MAX.80°C

COMMENT:

- 1.TMBF 6000h OR MORE @ 24V/300RPM
- 2.INSULATION RESISTANCE (NORMAL TEMPERATURE AND HUMIDITY): 100 Mohm
- 3.DIELECTRIC STRENGTH 500VAC FOR 1MIN.(BETWEEN THE MOTOR COILS AND THE MOTOR CASE)

STEPPER MOTOR
11HS20-1004D-E1000-EGS100
S/N: XXXXXXXXXXXX



MOTOR CONNECTION			
PIN NO	BIPOLAR	LEADS	WINDING
1	A+	BLK	
2	A-	GRN	
3	B+	RED	
4	B-	BLU	

ENCODER RESOLUTION:1000PPR(4000CPR)								
LEAD COLOR	WHT	RED	BLK	ORG	GRY	YEL	GRN	BLU
DESCRIPTION	EA+	VCC	GND	EB+	EB-	EA-	EZ+	EZ-

FULL STEP 2 PHASE-Ex.,WHEN FACING MOUNTING END (X)						CCW	CW
STEP	A+	B+	A-	B-			
1	+	+	-	-			
2	-	+	+	-			
3	-	-	+	+			
4	+	-	-	+			

DIMENSIONS ARE IN MILLIMETERS.
TOLERANCES AS BELOW:
DECIMALS ANGLES
X ±0.5 ±2°
X.X ±0.25
X.XX ±0.13

STEPPERONLINE®

GEARED STEPPER MOTOR

11HS20-1004D-E1000-EGS100

THIS DOCUMENT SHALL NOT BE REPRODUCED NOR SHALL THE INFORMATION CONTAINED HEREIN BE USED BY OR DISCLOSED TO OTHERS UNLESS EXPRESSLY AUTHORIZED IN BY WRITING STEPPERONLINE.

SIGNATURE		DATE
DRN	ZPJ	3.23.2026
APVD	LDJ	3.23.2026

REV.	0	SCALE	3: 2	DWG NO.	A6046
------	---	-------	------	---------	-------